

Mist **BLASTER**®

Super Efficient Mist Collection

Dramatically Reduce Operator Exposure!

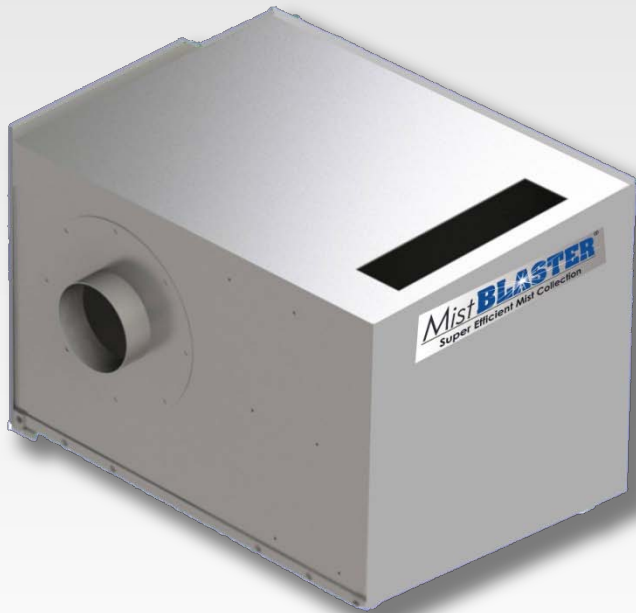

- Washable filters
- Low noise output (74 Db)
- Stand Alone Units or mounted with a ChipBlaster HP Unit
- Optional HEPA Filter

3 Optional Mounting Methods

- On top of ChipBLASTER unit
- On floor stand
- Hung from ceiling (via eye hooks)

Our Family of Integrated Machine Tool Accessories

ChipCHILLER®
High Performance Chillers



ChipBLASTER®
High Pressure Coolant Systems

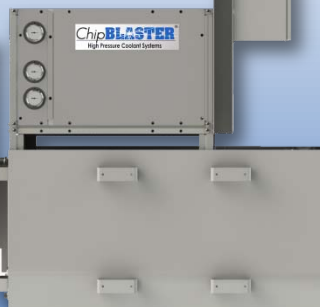

CentraBLAST®
Self Filtering Pumps



SkimBLASTER®
Oil Skimmers

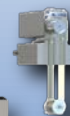

**One installation, One connection!
NO ADDITIONAL FLOOR SPACE!**



ISO 9001



ISO 14001

F-MKT-15.INT

Wertstrasse 23, 40549 Düsseldorf, Germany

8-06-14

Office: +49 (0) 211-56 94 91 84 • Fax: +49 (0) 211-56 94 91 83 • www.chipblaster.com

When the machine doors are closed our MistBLASTER runs at an ideal speed to prevent mist from escaping the machine enclosure. Virtually no mist escapes and operator exposure is dramatically reduced.

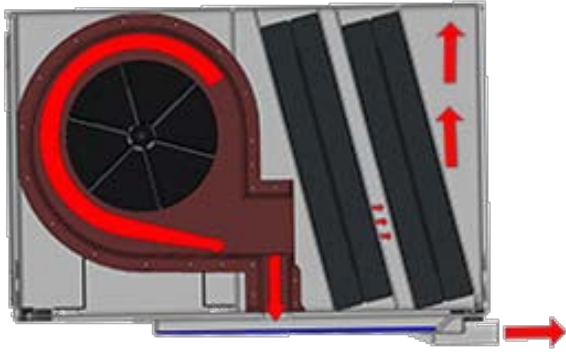

Unit Specifications:

Max Meter ³ /Minute	34 (1200 cfm)
Amperage	10 amps @ 230 VAC
Remote Location	Yes
Liquid Return	Yes
Weight	205 Kg. (450 lbs)
"M" code controlled.	

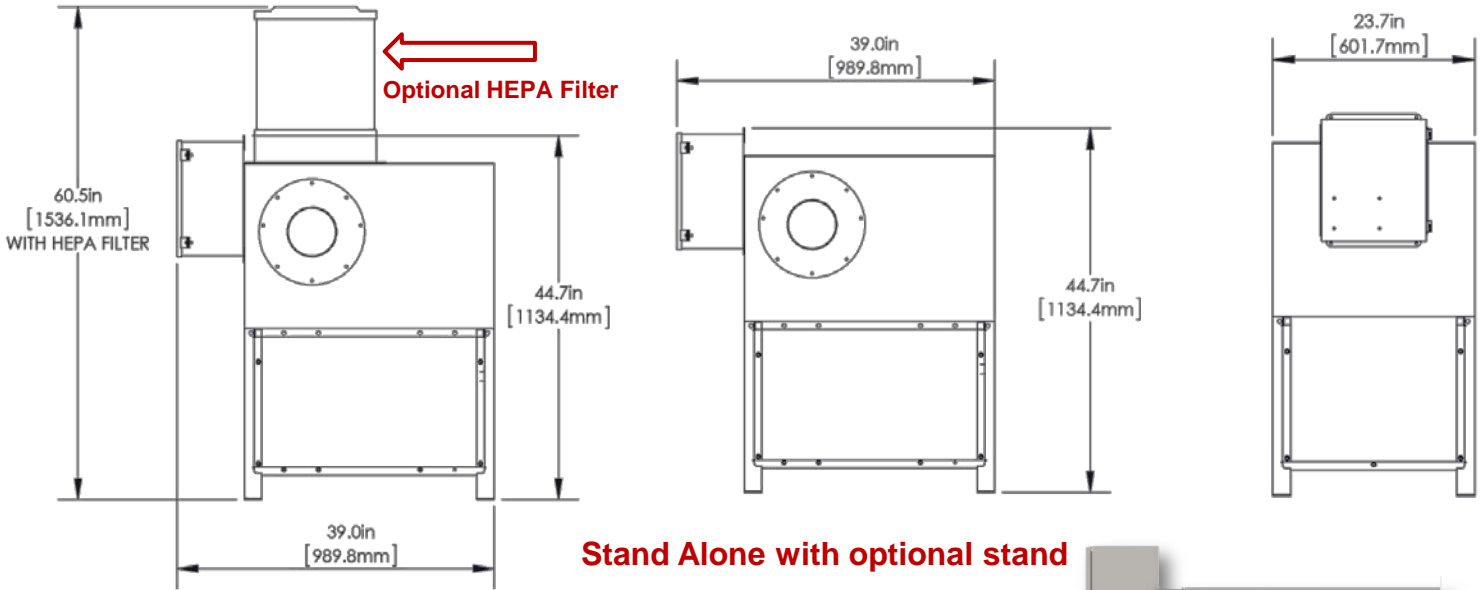

ChipBLASTER®

A Family of Integrated Machine Tool Accessories

- ChipBLASTER® High Pressure Coolant Systems
- BLASTVeyor® Self Cleaning Chip Conveyors
- ChipCHILLER® High Performance Chillers
- MistBLASTER® Super Efficient Mist Collection
- CentraBLAST® Self Filtering Pumps
- SkimBLASTER® Oil Skimmers

13605 S Mosiertown Rd, Meadville, PA 16335
 www.chipblaster.com 800-241-3163

Shown mounted on
ChipBLASTER®
 High Pressure Coolant Systems



Distributor Label