

D30-70

**30 lpm @ 70 bar
(8 gpm @ 1000 psi)**



- Dual Pleated Filters (10 Micron)
- Single "M" code controlled outlet
- Turret Index Signal

Ideal for machine tools up to 15 kw (20 HP) and 40 taper mills

Other Stand Alone Units Available

ChipCHILLER®
High Performance Chillers



BLASTVeyor®
Self Cleaning Chip Conveyors



Available in North America Only

SkimBLASTER®
Oil Skimmers

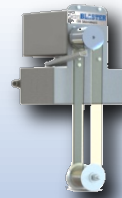

CentraBLAST®
Self Filtering Pumps

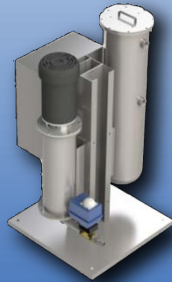

MistBLASTER®
Super Efficient Mist Collection

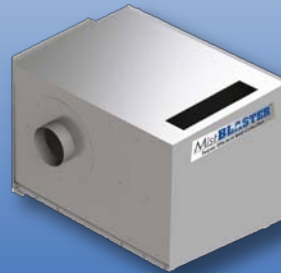

ISO 9001



ISO 14001



D MODEL STANDARD CONFIGURATION

ChipBLASTER "D" is pressure fed by the standard on board transfer pump, through the filter vessel, to the inlet of the positive displacement pump.

Key Features of the D30-70 High Pressure Module

- ChipBLASTER Super Duty Pump
Durable enough to offer an optional 2nd year parts warranty.
(Your ChipBLASTER ships with a standard 1 year parts and labor warranty).

- Sophisticated interaction with the machine tool
The ChipBLASTER is a process tool. Designed with automatic overload protection on the system as well as a dirty filter alarm circuit, we can insure a safe machining process without damage to the machine tool, the part, or tooling.

FEATURES	D30-70
Max gpm	30 LPM (8 GPM)
Max Bar (Pressure)	70 BAR (1000 PSI)
Run Dry Pump	Std
Transfer Pump	Std
Dual Filters	Std
Single Outlet	Std
Adjustable (PSI) Bar Valve	Std
Error Signal Output	Std
Dirty Filter Alarm Panel Light	Std

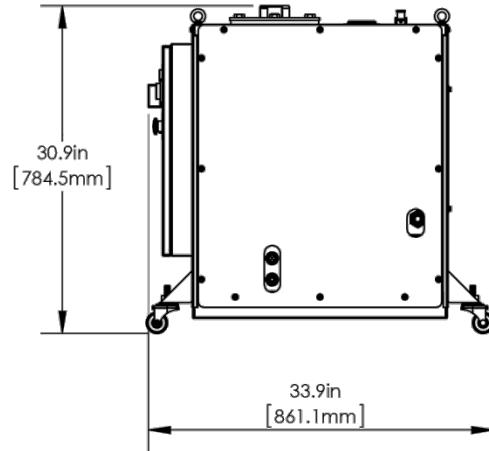
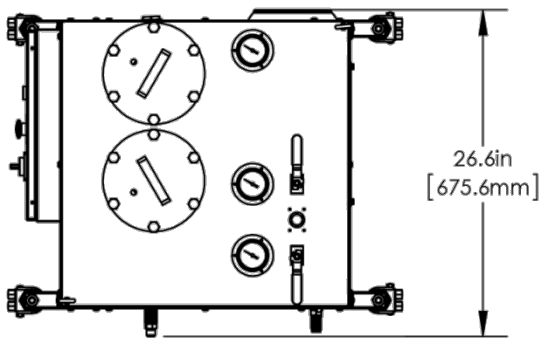

ChipBLASTER®

A Family of Integrated Machine Tool Accessories

- ChipBLASTER® High Pressure Coolant Systems
- BLASTVeyor® Self Cleaning Chip Conveyors
- ChipCHILLER® High Performance Chillers
- MistBLASTER® Super Efficient Mist Collection
- CentraBLAST® Self Filtering Pumps
- SkimBLASTER® Oil Skimmers

13605 S Mosiertown Rd, Meadville, PA 16335
www.chipblaster.com 800-241-3163

Distributor Label