

ChipBLASTER®

A Family of Integrated Machine Tool Accessories

J2-60

60 liters per minute

(16 gpm)

Pressure up to 83 bar

(1200 psi)

Flexibility

The J2-60 operates as two completely independent 30 liter (8 gpm) modules for dual turrets or as a single 60 liter (16 gpm) fixed volume unit.

For machine tools up to 30 kw (40 hp), dual turret lathes and 50 taper mills



380 liter/100 gallon tank is standard

Optional Integrated Accessories

MistBLASTER®
Super Efficient Mist Collection



Available in North America Only

ChipCHILLER®
High Performance Chillers



ChipBLASTER®
High Pressure Coolant Systems

CentraBLAST®
Self Filtering Pumps



SkimBLASTER®
Oil Skimmers



**One installation, One connection!
NO ADDITIONAL FLOOR SPACE!**



ISO 9001



ISO 14001

8-06-14

F-MKT-61.INT

Werftstrasse 23, 40549 Düsseldorf, Germany

Office: +49 (0) 211-56 94 91 84 • Fax: +49 (0) 211-56 94 91 83 • www.chipblaster.com

J2-60 STANDARD CONFIGURATION

The ChipBLASTER J2-60 is fed by a transfer pump that draws from the machine tool sump, through the filter vessel to the integral 380 liter (100 gal) tank. When the machine tool calls for coolant, the filter pump(s) draws the coolant from the ChipBLASTER tank and pumps through to the inlet of the positive displacement pump. The coolant then flows at high pressure through a series of distribution and safety valves and on to the machine tool.

Key Features of the J2-60

•Double Compression Filter Hold Down

ChipBLASTER has created the most efficient bag filtration on the market today. Our double compression filter hold down lid protects both our system and the machine tool from contamination.

•ChipBLASTER's Super Duty Pump

is designed for coolant. It is durable enough that we offer an optional 2, 3, 4, or 5 year warranty.

•A Full Range of Safety Features

Safety Features insures a safe machining process without damage to the machine tool, the part, or tooling. We can meet or exceed all international requirements for operator and machine tool protection with integrated automatic overload protection as well as many alarm circuits.

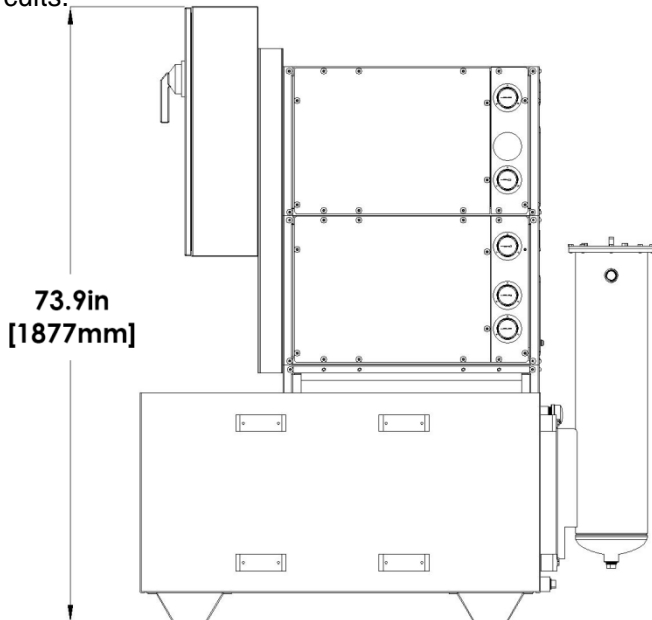

Popular Options for the J2-60

•Display (HMI)

Displays the current status of the ChipBLASTER and any faults. The PLC allows for display of the last 8 faults on the ChipBLASTER unit, as well as filter status, unit run time, and automatic "B" filter purges on units with automatic filter crossover.

•Extended Warranty

2, 3, 4, and 5 year parts warranty for your ChipBLASTER is available. (Your unit has a standard 1 year parts and labor warranty)

•Dual Filters

Allows filter changes "in-process" eliminating machine tool down time.

•Simple Low Cost Installation Kits

Installation kits allow "plug and play" installation. Engineered packages are available for most machine tools. Please contact ChipBLASTER for details.

•Auto Filter Crossover

This system automatically will switch from dirty filter "A" to filter "B" and set off an alarm light alerting the operator that the filter needs to be changed at your convenience.

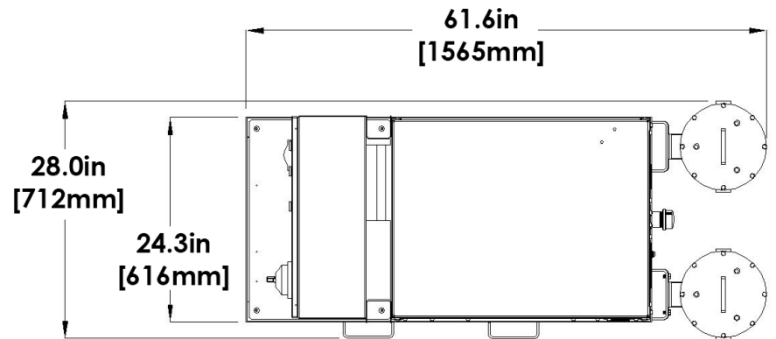

ChipBLASTER®

A Family of Integrated Machine Tool Accessories

ChipBLASTER® High Pressure Coolant Systems
BLASTVeyor® Self Cleaning Chip Conveyors
ChipCHILLER® High Performance Chillers
MistBLASTER® Super Efficient Mist Collection
CentraBLAST® Self Filtering Pumps
SkimBLASTER® Oil Skimmers

13605 S Mosiertown Rd, Meadville, PA 16335
www.chipblaster.com 800-241-3163

Distributor Label